

Frozen
Frozen granita, creams and soft-ice
cream dispenser with 2 bowls and touch
screen, UK plug

ITEM # _____

MODEL # _____

NAME # _____

SIS # _____

AIA # _____



562529 (GT2TR290)

* NOT TRANSLATED *

Main Features

- Can dispense up to 5 products among soft ice cream, frozen yogurt, chilled coffee cream, sorbet or slush.
- Can be used in specialised ice cream shops to dispense products specifically conceived for particular customer categories, like celiac or people who are lactose intolerant. Producing ice-cream with this equipment prevents any contamination, as the bowls d
- Ideal for bars, restaurants, hotels, cafeterias and catering companies for the production of delicious desserts and chilled specialties.
- The ITANK™ Technology prevents ice accumulation on the outer side of the bowl.
- Menu is available in Italian and English, but other languages can be programmed as well.
- Customizable touch screen display.
- Easy to use thanks to the adjustable push button control panel: when pressing it the rotation spees raises and the product is pushed out easily.

APPROVAL: _____

Front

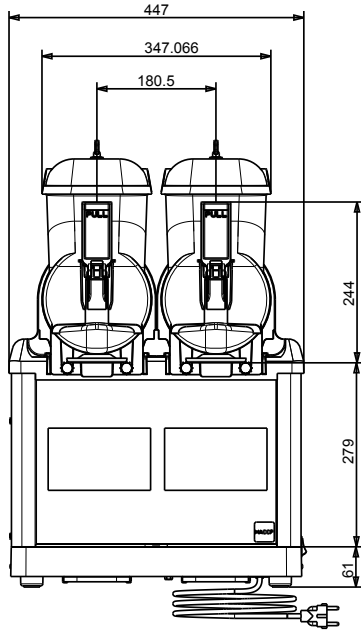

Side

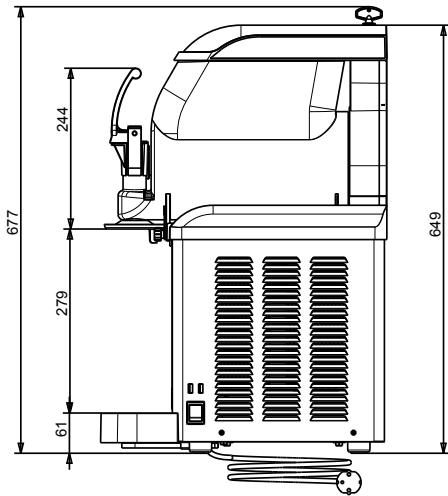

Top

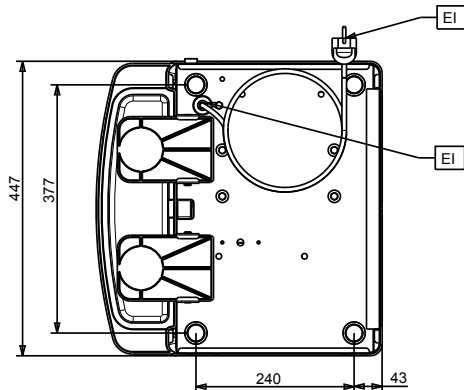

Electric

Supply voltage:

562529 (GT2TR290) 220-240 V/1 ph/50 Hz

Electrical power max.:

0.6 kW

Key Information:

External dimensions, Width: 450 mm

External dimensions, Depth: 435 mm

External dimensions, Height: 650 mm

Net weight: 46 kg

Sustainability

Refrigerant type: R290

Refrigerant weight: 102 g